

APECS™ 0175

Linear Actuator with External Linkage

Description

APECS™ 0175 linear actuators deliver precise positioning and form the foundation of a full electronic governing system. Many of the moving parts normally associated with electric actuators are eliminated, prolonging the MTBF (mean time between failure).

The actuator design employs the principle of variable reluctance for consistent force over the entire stroke. This simple design of a proportional electric linear actuator utilizes a linear armature whose magnetic force is proportional to the input current to the coil.

These actuators are easy to install by mounting near the fuel system with a direct connection to the fuel control rod or level. In most installations, the normal rotary-to-rotary connection is eliminated, resulting in a more trouble-free and accurate control system.

APECS 0175 actuators are suitable for installation on diesel, gasoline, or natural gas engines with fuel system force requirements of less than 4.0 pounds (17.8 N) of force.

Woodward also manufactures 0175 actuators integral to the engine block or fuel pump. For details on these purpose-built actuators visit www.woodward.com to access Product Specification 37744.

Applications

Provides proportional fuel control for construction, industrial, and agricultural equipment. 1.75-inch (44.4 mm) diameter spring-return actuator, pull or push models, three spring types available.

Electrical Specifications

Stroke	0.75 inch (19 mm) minimum
Force	3.5 lb (15.6 N) @ 23 °C (with SI spring, normal current)
Work Rating	0.3 lb-ft (0.4 N-m)
Nominal Rated Current	4.3 A (12 V [dc]); 2.3 A (24 V [dc])
Response Time	30 ms for 10 % to 90 % of stroke
Resistance (nominal)	2.80 Ohms (12 V); 10.63 Ohms (24 V)

Mechanical Specifications

Operating Temperature	−40 °F to +185 °F (−40 °C to +85 °C)
Vibration	15 G's (3 planes, 1 h/plane 50 Hz to 1000 Hz sweep; 3 planes, 1 h/plane at first resonant frequency)
Shock	Designed for US MIL-STD-810F, Method 516.5, Section 4.5.2: Procedure 1: 40 G peak



- All-purpose, externally mounted
- Pull or push actuation
- Flange or base mount
- Internal spring return to minimum fuel position
- Corrosion-resistant, plated steel housing, and base or flange
- Precise engine speed control when used with APECS electronic controllers
- Variety of mounting styles, plungers, terminations, and springs available

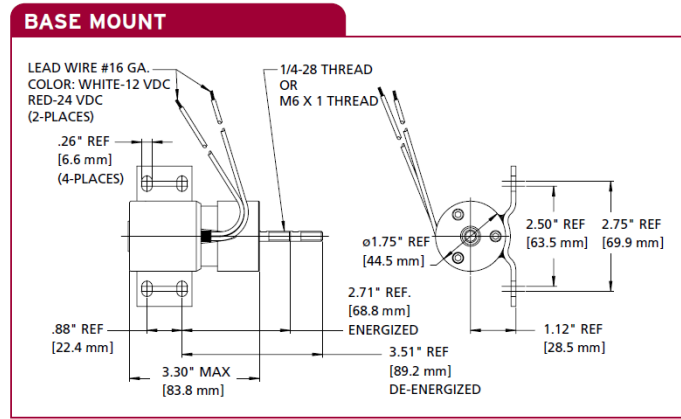
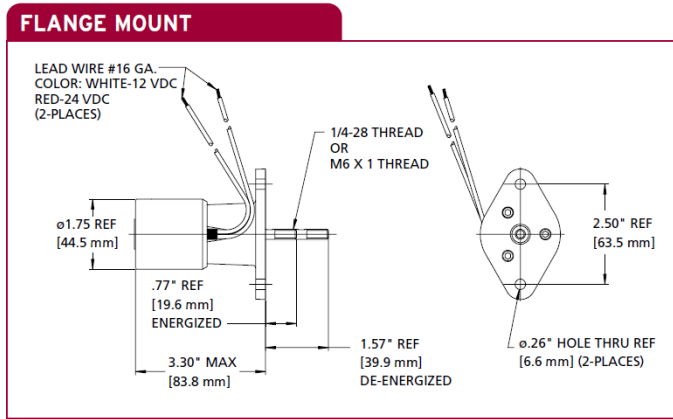

0175 / Pull Actuation

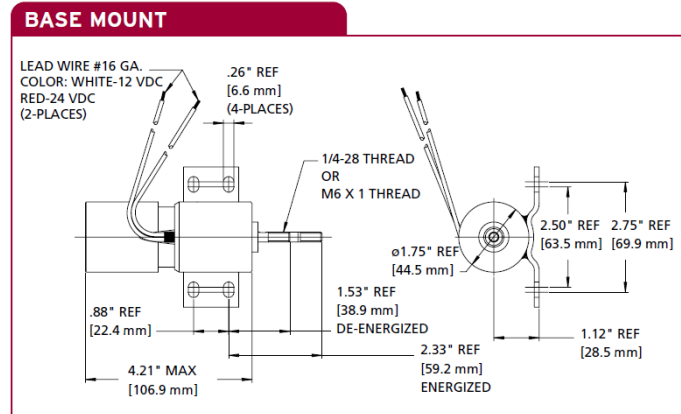
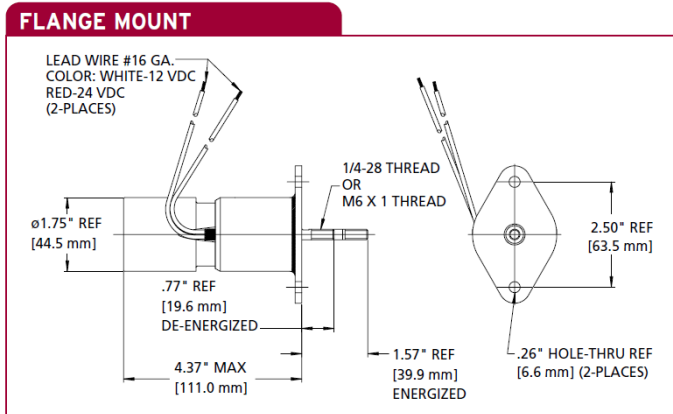

0175P / Push Actuation

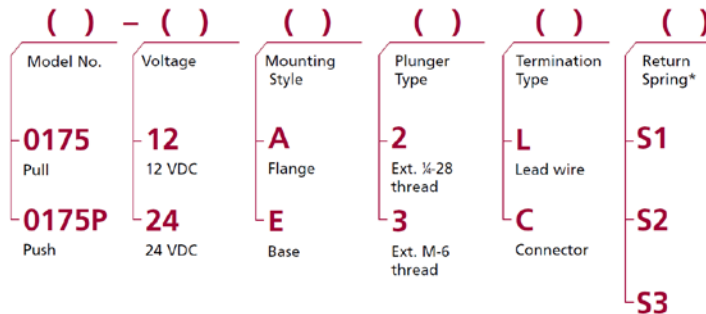

Order Information—Complete the following model descriptions to build your order number:

Spring Type	PART NO.	De-energized Spring Force	Energized Spring Force	Spring Rate
S1	SA-4703	0.50 lbs (2.2 N)	5.25 lbs (23.4 N)	5.94 lbs/in (0.16 kg/mm)
S2	SA-4704	0.25 lbs (1.1 N)	6.00 lbs (26.7 N)	7.20 lbs/in (0.13 kg/mm)
S3	SA-4472	0.40 lbs (1.8 N)	1.60 lbs (7.1 N)	1.53 lbs/in (0.03 kg/mm)

Spring Chart (at ambient temperature)



PO Box 1519, Fort Collins CO, USA 80522-1519
1000 East Drake Road, Fort Collins CO 80525
Tel.: +1 (970) 482-5811 • Fax: +1 (970) 498-3058
www.woodward.com

Distributors & Service

Woodward has an international network of distributors and service facilities. For your nearest representative, call the Fort Collins plant or see the Worldwide Directory on our website.

This document is distributed for informational purposes only. It is not to be construed as creating or becoming part of any Woodward contractual or warranty obligation unless expressly stated in a written sales contract.

For more information contact: